

# Application of Inductively Coupled Wireless Radio Frequency Probe to Knee Joint in Magnetic Resonance Image

Shigehiro HASHIMOTO, Tomohiro SAHARA, Hiroshi TSUTSUI,  
Shuichi MOCHIZUKI, Yuki KATAYAMA

Department of Biomedical Engineering, Osaka Institute of Technology, Osaka, 535-8585, Japan  
hashimoto@bme.oit.ac.jp <http://www.oit.ac.jp/bme/~hashimoto>

and

Yuichirou MATSUOKA

Internal Medicine, School of Medicine, Kobe University, Kobe, Japan

and

Takashi NISHII

Department of Orthopaedic Surgery, Osaka University Medical School, Osaka, Japan

and

Kagayaki KURODA

Department of Information Technology and Electronics, Tokai University, Hadano, Japan

## ABSTRACT

An inductively coupled wireless coil for a radio frequency (RF) probe has been designed and applied to a human knee joint to improve the signal to noise ratio (SNR) in a magnetic resonance image (MRI). A birdcage type of a primary coil and a Helmholtz type of a wireless secondary coil have been manufactured. The coils were applied to a human knee with a 3 T MRI system. SNR was calculated both in the proton density image and in the T2 weighted image of MRI. The experimental results show that the designed coils are effective to increase SNR in the human knee MRI.

**Keywords:** Biomedical Engineering, Magnetic Resonance Image, Radio Frequency Probe, Signal to Noise Ratio, Inductively Coupling, Wireless Coil and Knee.

## 1. INTRODUCTION

A magnetic resonance image (MRI) system creates an image with signals from an excited subject at high frequency. Its detector is called a radio frequency (RF) probe, because the frequency belongs to the range of radio frequency. The RF probe governs the quality of the image [1].

A wireless RF coil works through inductive coupling, and has been applied in MRI systems [2]. Graf et al. developed a wireless probe inductively coupled with a volume type of RF coil of a 1.5 T MRI system for the head [3]. They applied the

probe to small animals, and showed that MRI can be taken with high signal to noise ratio (SNR).

In the present study, an inductively coupled wireless coil for the radio frequency (RF) probe has been designed and applied to a human knee joint to improve the signal to noise ratio (SNR) in the magnetic resonance image (MRI).

## 2. METHODS

### RF probe

Signa3.0T VH/LX ver8.3m4 (GE Healthcare) was used for the MRI system (Fig. 1). The RF probe consists of two coils: a primary coil and a secondary coil (Fig. 2). The bidirectional primary coil is a birdcage type, which has eight legs of 8 mm width each (Fig. 3). It has a cylindrical shape with 250 mm diameter and 300 mm height. The primary coil generates a linear drive type of magnetic field. The secondary coil is a Helmholtz type with the dimension of 120 mm diameter and 120 mm height (Fig. 4). The secondary coil is inserted into the primary coil, which has an electric feeding point for transmission and reception of signals.

For the MRI system of 3.0 T, the resonance frequency is adjusted to 127.7 MHz with capacitance in the electric circuit. The excitation efficiency increases, when the resonance frequency of the secondary coil is same as that of the primary coil. The frequency was measured with the radio frequency network analyzer (Agilent Technologies, 8712ET).



**Signa 3T BH/i, LX ver8.3m4**

**Fig. 1:** MRI system.

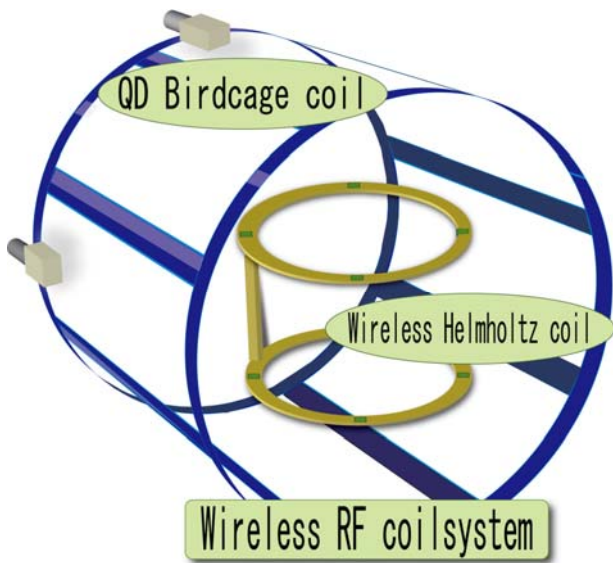

**Fig. 2:** Two coils system.

**Signal to Noise Ratio**

The signal to noise ratio (SNR) in inductively coupled coils is a function of a mutual inductance ( $m$ ), a resonance frequency ( $f$ ), and a resistance of a primary coil ( $R_p$ ) (Fig. 5). The SNR increases, when the product of the mutual inductance and the resonance frequency is larger than the resistance of the primary coil. A wireless coil uses “Critical coupling” [4]. The resonance frequencies on the primary and the secondary coils are condensed to the same value at Critical coupling (Fig. 6). Resonating between the primary and the secondary coils improves the excitation efficiency.

$$R_p \ll mf \tag{1}$$

The methodology to calculate SNR from  $I$  (the mean intensity of the signal in the region of interest) and  $B$  (the standard deviation of the mean intensity in the background) in equation (2) is based on the National Electric Manufacturers Association (NEMA) standards.



**Fig. 3:** Primary coil.

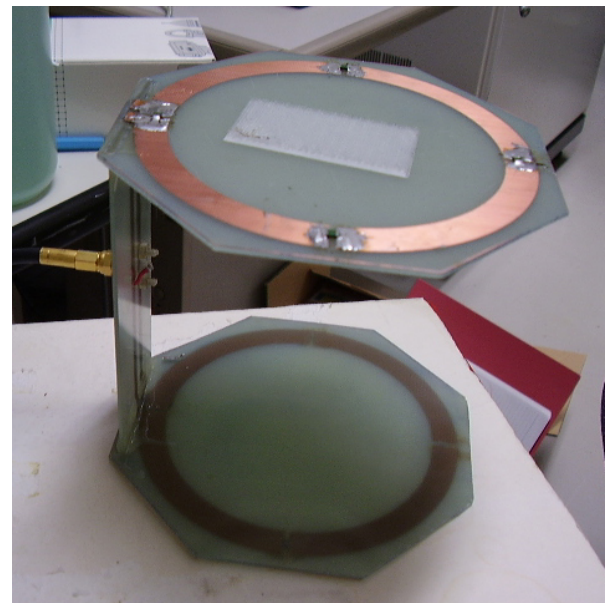

**Fig. 4:** Secondary coil.

$$SNR = I / B \tag{2}$$

The standard deviation in the background is calculated on the image composed from differential signal between two images with the same parameter.

**Human Knee Study**

The measurement system was applied to a normal knee of an adult human volunteer (Fig. 7).

The proton density image and T2 weighted image of magnetic resonance were taken at the knee with and without the wireless coil. The imaging condition was as follows: fast spin echo,

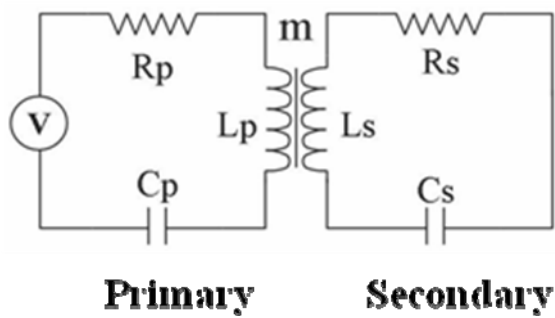

Fig. 5: Inductively coupled coils.

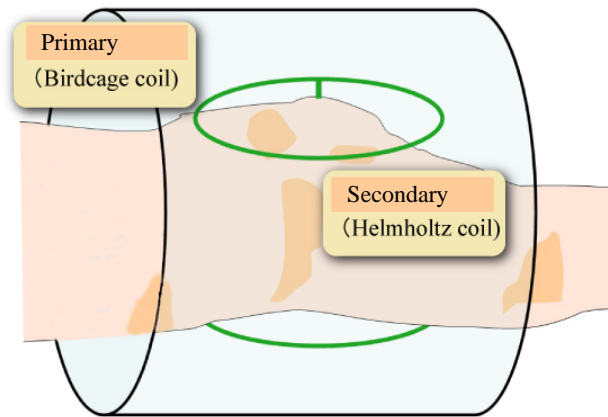

Fig. 7: Application to human knee.

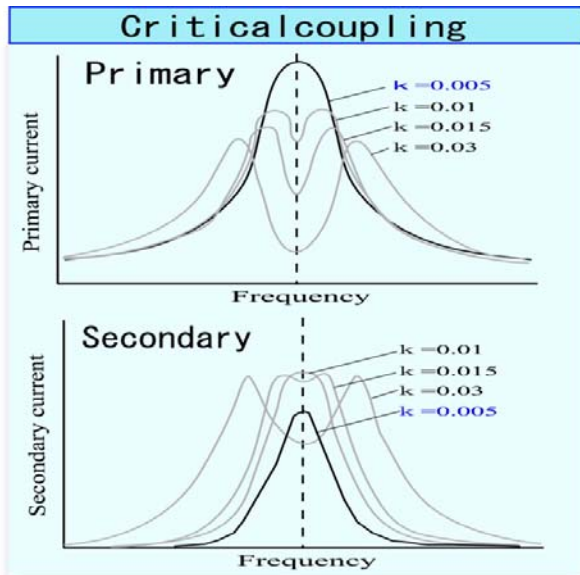

Fig. 6: Critical coupling between two coils.

double echo, the sagittal views, echo train length (ETL) = 8. SNR was calculated for the knee study.

### 3. RESULTS

Fig. 8 shows the proton density images of the knee with and without the wireless coil, and Fig. 9 shows the T2 weighted images of the knee with and without the wireless coil. The upper picture shows the image without the wireless coil, and the lower picture shows one with the wireless coil in Figs. 8 and 9.

The calculated SNR values are illustrated for the proton density image and for the T2 weighted image at selected five regions (Fig. 10) in MRI in Fig. 11. The results show that SNR increases with the wireless coil both in the proton density image and in the T2 weighted image. The SNR doubles with the wireless coil probe at “point 1 (Fig. 10)” of the cancellous bone. The increasing rate of SNR with the wireless coil is also more than one hundred percent at “point 2 (Fig. 10)” of cartilage in the proton density image, while that with the wireless coil is small at “point 2” of cartilage in T2 weighted image.



Fig. 8: Proton density images of knee. Upper, without the wireless probe; Lower, with wireless probe.

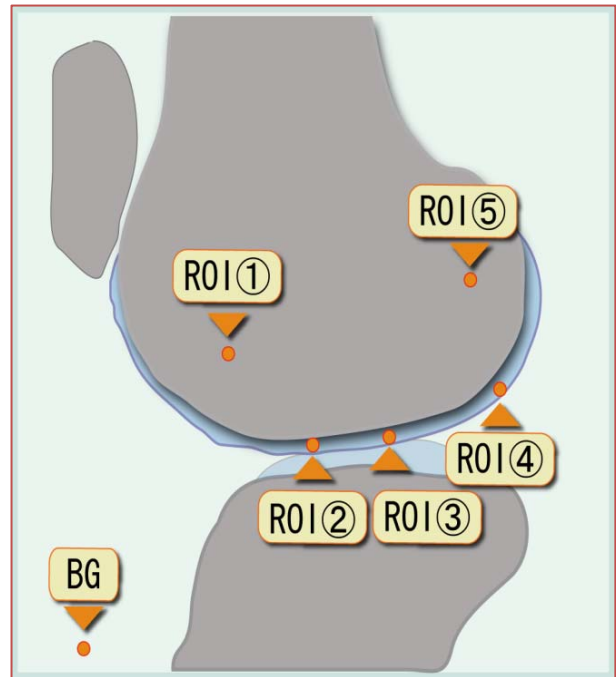

**Fig. 9:** T2 weighted images of knee. Upper, without the wireless probe; Lower, with wireless probe.

#### 4. DISCUSSION

There are several ways to improve resolution in MRI: one is to increase the resonance frequency, and another is to increase SNR. Increase the resonance frequency has an advantage to improve resolution of MRI, but has disadvantage to decrease the specific absorption rate.

Fitting the secondary wireless coil increases the magnetic filling factor, which improves SNR. Morphological preciseness of the coils would provide a uniform magnetic field, which improves MRI in the present system with the secondary wireless coil.



**Fig. 10:** Five regions (ROI Number in Fig. 11) for SNR calculation. BG, back- ground.

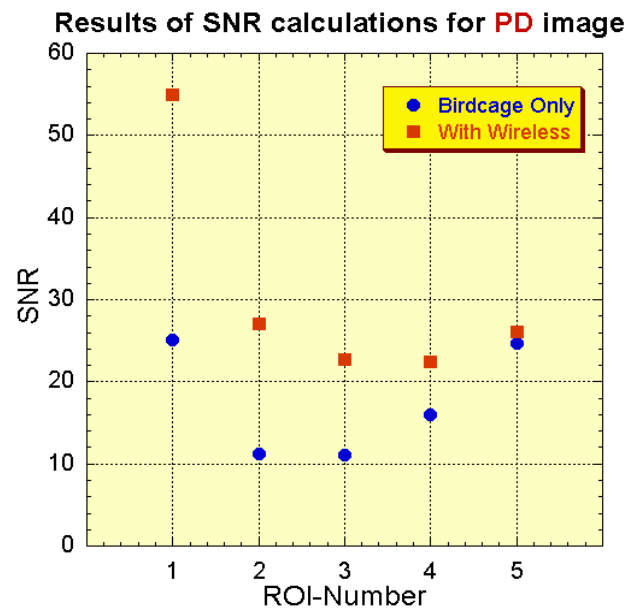

**Fig. 11(a):** Signal to noise ratio (SNR) at each region (ROI Number in Fig. 10) for proton density image.

The designed coil is simple and easily applied to a conventional magnetic resonance image system.

The uniformity decreased in the part of the background image with the secondary coil in the present experiment. The uniformity of the magnetic resonance image might depend on the shape of the secondary coil, when a wireless radio frequency coil system is applied.

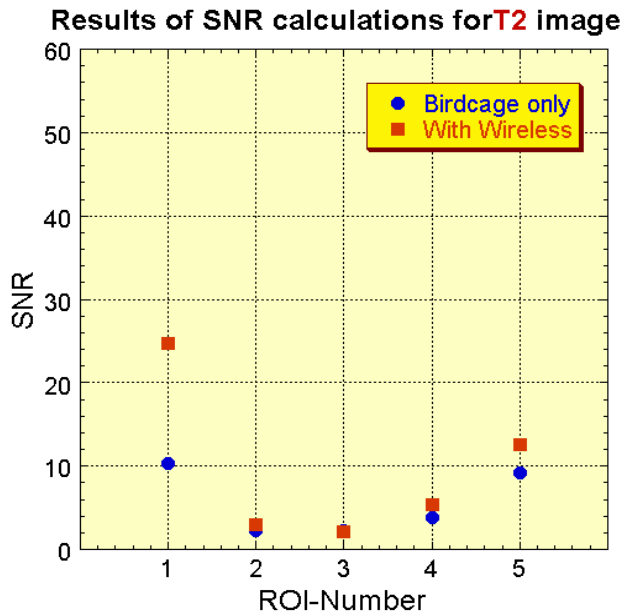

**Fig. 11(b):** Signal to noise ratio (SNR) at each region (ROI Number in Fig. 10) for T2 weighted image.

The SNR is able to increase with the secondary coil, because the combination between the magnetic flux induced by the primary coil and that induced by the secondary coil might increase the signal current of the primary coil [5, 6].

The SNR with the wireless coil was small at “point 2” of cartilage in T2 weighted image (Fig. 11(b)). The chemical shift might make the identification of the cartilage difficult.

## 5. CONCLUSION

An inductively coupled wireless coil for a radio frequency probe has been designed and applied to a human knee joint to improve

the signal to noise ratio in the magnetic resonance image. The experimental results show that the designed coils are effective to increase the signal to noise ratio in the human knee MRI.

## 6. ACKNOWLEDGMENT

This work was supported in part by a Grant-in-Aid for Scientific Research from the Japanese Ministry of Education, Culture, Sports, Science and Technology.

## 7. REFERENCES

- [1] C. N. Chen, D. I. Hoult, **Biomedical Magnetic Resonance Technology**, Adam Hilger, 1989.
- [2] M. D. Schnell, C. Barlow, V. H. Subramanian and J. S. Leigh, “Wireless Implanted Magnetic Resonance Probes for in vivo NMR”. **J Magn Reson**, Vol. 68, 1986, pp. 161-167.
- [3] H. Graf, P. Martirosian, F. Schick, M. Grieser and M. E. Bellemann, “Inductively Coupled RF Coils for Examination of Small Animals and Objects in Standard Whole-Body MR Scanners”, **Medical Physics**, Vol. 30, No. 6, 2003, pp. 1241-1245.
- [4] K. Henny, **Radio Engineering Handbook**, McGraw-Hill, 1959.
- [5] M. Bilgen, “Inductively-Overcoupled Coil Design for High Resolution Magnetic Resonance Imaging”, **Biomedical Engineering OnLine**, Vol. 5, No. 3, 2006, 10 pages.
- [6] T. Sahara, S. Hashimoto, K. Nakamura, H. Tsutsui, K. Akazawa, S. Mochizuki, Y. Matsuoka, T. Nishii, K. Kuroda, “Radio Frequency Probe for Improvement of Signal to Noise Ratio in Magnetic Resonance Image with Inductively Coupled Wireless Coil”, **Proc. 12th World Multiconference on Systemics Cybernetics and Informatics**, Vol. 4, 2008, pp. 172-176.