

# Soft Computing for Human Spermatozoa Morphology

Jia Lu

Computer Science and Information System,  
University of Phoenix, U.S.A  
5050 NW 125 Avenue, Coral Spring, FL 33076, USA

Yunxia Hu

Department of Health Science  
Nova Southeastern University, U.S.A  
2960 N. State Road 7, Suite 300, Margate, FL 33063

## ABSTRACT

A fuzzy data fusion approach was used for human sperm morphology recognition analysis using 3-CCD camera image data. Fuzzy operators were used to create the relationship between abnormal sperm morphology and normal sperm aberrations after digitizing the images. The approaches have focused on frequencies of sperm with either abnormal morphology in semen analysis samples. In order to establish whether various shapes of membership functions, the authors would classify the morphology according to their head, tail, and neck shapes into symmetrical, asymmetrical, irregular and amorphous categories based on the fuzzy region. The images results demonstrated how these findings facilitated approaches on the 100 semen samples. The average probability of morphology recognition analysis was equal to 95% and the average probability of unknown parameter was equal to 4.5%. The fuzzy fusion morphology provided a unified and consistent framework to express different shapes of human spermatozoa.

**Key words:** Fuzzy Data Fusion, Sperm Morphology, soft computing, imaging processing, fuzzy rule

## 1. INTRODUCTION

The goal of estimating correctly a man's fertility potential has long been of great interest to the research. Human sperm morphology is assessed routinely as part of standard laboratory analysis in the diagnosis of human male infertility. This practice has its origins in the work of Seracchioli [1] which showed that sperm morphology was significantly different in fertile compared to infertile man. The evaluation of human sperm morphology has been a difficult and inconsistent science since it is based on the individual sperm parameters. The difficulty in classifying human sperm morphology is mainly caused by the large variety of abnormal forms found in the semen of infertile men. There are many approaches to human sperm morphology recognition available, and some of them have been applied to real world tasks with great success [2]. Complete assessment of human sperm shape includes analysis of the head, neck, midpiece, and tail. In general, clinical laboratories use the sperm morphology parameters. One of the biochemical parameters is the concentration of the enzyme creatine phosphokinase in sperm, which reflects cytoplasmic retention that the individual spermatozoa has demonstrated a relationship among the

abnormal sperm morphology, including larger head size, roundness of the head, and increased proportion of amorphous heads [3]. However, these evaluations for human sperm morphology are normally hard to establish and human knowledge is hard to incorporate into the precision levels. Human semen evaluation continues to be influenced by subjectiveness of the investigator and a lack of objective measurements for sperm morphology continues to be a problem.

Fuzzy set theory provides a good theoretical basis to represent imprecision of information, in particular in image processing and interpretation. Fuzzy data fusion deals with the integration of information from several different sources. The necessity to fuzzy data fusion arises quite naturally in problems of image understanding because imprecision, uncertainty and ambiguity can be found at all levels, from the image itself to the results of high-level processing [4]. In addition individual visual cues are often unreliable, even misleading. Thus integration of vision modules is necessary to obtain a reliable interpretation of complex images. Considering the ambiguous, complementary, and redundant shapes of different sperm color image, the fuzzy logic and fuzzy data fusion technique is a good choice to use to analyze the sperm morphology. A fuzzy data fusion approach was based on image understanding applications that it must be capable of integrating uncertain information from a variety of individual sperm morphology. Fuzzy data fusion is especially suited to provide methods to deal with and to fuse uncertain and ambiguous data arising in computer vision [5]. Fuzzy logic theory has already turned out to be a valuable tool for the solution of various single tasks in image understanding [6]. These successful applications of fuzzy notions stimulate the idea that the integration of single vision modules using fuzzy methods will result in a powerful fuzzy data fusion system.

In this paper, we present a general approach of processes and representations in 3-CCD camera image recognition for those individual sperm using the theory of fuzzy data fusion. To evaluate the sperm shapes, it is necessary to utilize multiple color images for finding some of its properties. The result evidence suggests that sperm morphology assessment by relatively simple and inexpensive methods provide prognostic information similar to that obtained from some of the more elaborate sperm function tests.

## 2. HUMAN SPERM MORPHOLOGY

Human morphological slides were prepared using smearing and staining technique in order to create imaging analysis for fuzzy fusion (Figure 1). Human sperm showed

large variation in morphology during the observation on sperm analysis done manually (Figure 2). The morphological abnormalities normally relate to the main regions of the spermatozoon (i.e. head, neck/mid-piece, and tail).



**Figure 1. Human sperm smear and stain morphology slides.**



**Figure 2. Various shapes of human sperm.**

Large, small, tapered, pear-shaped, round, amorphous, and vacuoles were shown as head defects. There were bent, asymmetrical tail insertion, thick or irregular mid-piece or thin mid-piece in neck, and mid-piece abnormalities. Short, double, hairpin, broken, bent, irregular width or coiled morphologies were shown as tail defects.

Fuzzy data fusion was performed based on various sperm head, mid-piece, and tail defects. Small acrosomal area or double heads sperm and free tails were not computed. A high frequency of coiled tails indicated that the sperm had been subjected to hypo-osmotic stress. Tail coiling related to sperm aging. A frequency of coiled tails was computed in fuzzy data fusion.

### 3. FUZZY FUSION BEHAVIOR

The most obvious illustration of fusion is the use of various sensors typically to detect a human sperm images. Fuzzy data fusion was used for recognition of the human sperm properties. The processes for the experiment are often categorized as low, intermediate and high level fusion depending on the processing stage at which fusion takes place.

#### 3.1 Fuzzy Data Fusion:

It combines several sources of sperm morphology data to produce new data that was more informative and synthetic of the inputs. Typically, the images presented several spectral bands of the same scene fused to produce a new image that ideally contained in a single channel of all of the information available in spectral smear. An operator (or an image processing algorithm) could then use this single image instead of the original images. This is important when the number of available spectral bands becomes large to look at images separately. This kind of fusion requires a precise pixel level of the available images. Human beings, usually do not make this classification on the basis of their global interpretation capabilities.

#### 3.2 Feature Level Fusion:

The feature level fusion combines various features. Those features may come from several raw data sources or from the same data sources. The objective was to find relevant features among available features that might come from several feature extraction methods. Typically, in image processing, feature maps were computed as pre-lines, texture parameters that were computed and combined in a fused feature map for sperm shape recognition.

#### 3.3 Fuzzy Decision Fusion:

It combines decisions coming from several experts. Fuzzy logic based methods was used in the research. Human sperm morphology information fused was captured from multi-smear images. The individual sperm information source corresponded to different microscope sequences of the sperm sample. According to the head size, body, and tail quantization level in different slides of selection path during the process of image capture, the data alignment was transformed for the multiple source data into a common coordinate system. The human sperm data was modeled by fuzzy modeling correspond to multiple sources of feature fusion, fuzzy data fusion, and fusion decision in fuzzy fusion behavior (see Figure 3).

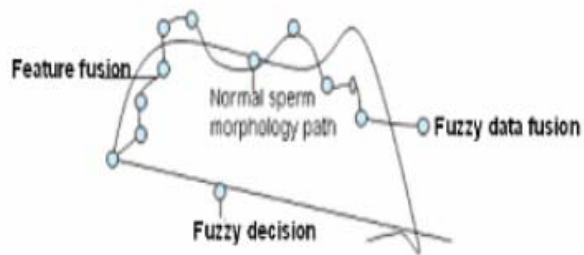

**Figure 3. Fuzzy fusion behavior.**

### 4. FUZZY RECONIZATION

#### 4.1 Human Sperm Defined as Fuzzy Integral and Fuzzy Sets:

Definition 1: Let  $S$  be a fuzzy location with the element of  $S$  denoted by  $s$ , in this case,  $S = (s)$ .  $S$  is the set of human sperm volume and  $s$  is the coordinate of shape,  $s = (a, b, c)$ .

Definition 2: Let fuzzy set  $A$  be a fuzzy subset on  $S$ ,  $A = (s, \mu_A(s)|s \in S)$ .  $A$  is a fuzzy set for human sperm of  $S$ .

Definition 3: Let  $X$  be a universal set for the sperm image, where  $D = (d)$ ,  $D$  is the fuzzy index of multi-smear.  $X$  provides

the H (head) when  $d = 1$ , N(neck) when  $d=2$ , T (tail) when  $d=3$ , and  $X$  is the set of signal intensity of image. The element of  $X$  is denoted by  $s_d$ .

Definition 4: Let the fuzzy set  $AX$  be a fuzzy set of the human important sperm defined as  $AX = ((s, d), \mu_{AX}(s,d) | s \in S, x_d \in X)$ . For the fuzzy integral measurement of human reproductive sperm, I need observe the image by the following definitions.

Let  $Z$  be a non-empty finite set.

Definition 5: An objective set function  $s: 2^Z \rightarrow [0, 1]$  is a fuzzy measurement if

- $s(\emptyset) = 0; s(Z) = 1$ ,
- if  $I, J \subset 2^Z$  and  $I \subset J$  then  $s(I) \leq s(J)$ ,
- if  $I_n \subset 2^Z$  for  $1 \leq n < \infty$  and the sequence  $\{I_n\}$  is the monotone in the sense of inclusion.

Definition 6: let  $s$  be a fuzzy measurement on  $Z$ . The function  $h: Z \rightarrow R$  with respect to  $s$  is defined as

$$\{h(z_1), \dots, h(z_n)\} = \sum_{i=1}^n \{h(z_i) - h(z_{i-1})\} s(I_i) \quad (1)$$

where indices  $I$  have been defined  $0 \leq h(z) \leq h(z_1) \leq 1, I = \{z_1, \dots, z_n\}; h(z_0) = 0$ .

#### 4.2 Fuzzy Model:

Fuzzy models were proposed for the fuzzy information. The membership functions of human sperm corresponding to H, N, and T,  $\mu_H, \mu_N$ , and  $\mu_T$  were defined in equation (2),

$$\mu_H^2(s, h) = \frac{1}{2} + \frac{1}{2} \sin((h_2 - (s+h)/2) \times s / (h-s)) \quad (2)$$

The membership functions of fuzzy models were used to analyze the feature of the parameter increasing of the operator. Membership functions present the relation of the degree of the sperm shape levels. They project the fuzzy feature of human sperm image onto corresponding fuzzy of H, N, and T.

The knowledge rules were used for the fuzzy models. A combination of the sperm features, the membership function with high degree of H:  $H \times N \times T \rightarrow [0, 1] \mu_H(s)$  if and only if  $s \in H$  where  $d = 1, 2, 3$ . The analysis of these features was based on any fuzzy intersection operator for fusing these features. Fuzzy starts with the fuzzification process of the given image yielding a fuzzy image defined in equation 3,

$$F_H = \{\mu_H(H_{dn}); d=0,1, \dots, d-1, n=0,1, \dots, N-1, 0 \leq \mu_H \leq 1\} \quad (3)$$

where  $\mu_H(H_{dn})$  is the membership functions that denote the degree of the brightness relative to the value of a pixel  $H_{dn}$  which is situated position of the given image. The membership functions were used to model the ambiguity in the image. Although there exist some different type of membership functions, it has been widely applied to image problems. This function was still defined as the following equation (4),

$$\mu_H(H_{dn}, a, b, c) = \{1 - 3[(H_{dn} - a)/(c - a)]^3 b < H_{dn} \leq c\} \quad (4)$$

where  $b = (a + c) / 2$  is the crossover point. The bandwidth of the membership function was defined as  $F = b - a = c - b$ . It determines the fuzziness in  $\mu_H$ .

#### 4.3 Fuzzy Fuzzification:

A fuzzy fuzzification was proposed for several fuzzy subsets by using fuzzy set. A fuzzy relation of human sperm was applied to interior region connection in subset and exterior region between subsets. After fuzzification, a fuzzy measure

was calculated to determine the average amount of ambiguity using a linear or quadratic index of fuzziness, a fuzzy entropy or an index of non-fuzziness measure. The index reveals the ambiguity in the given images (H)(N)(T) by measuring the shapes between its fuzzy property  $\mu_H, \mu_N, \mu_T$  and the nearest binary version  $\mu_H, \mu_N, \mu_T$ . Since the aim of the fuzzification is to determine the object from the properties of human sperm, the optimal images can be determined by minimizing the ambiguity in the given image. To determine the minimum ambiguity the crossover point, the bandwidth of the membership functions varies along the all shape levels of human sperm. We simulated the average percentage normal and percentage abnormal and selected the larger of those two groups for duplicate comparison. We computed the difference between the two assessments in that group. If the difference was smaller than the value obtained from fuzzy membership function computing, the assessments could be accepted. If the difference was larger than the value, two new assessments should be simulated. For the soft computing, we need check whether the smear was difficult to read from the computing, the smearing kept in reserve should be stained with fresh solutions and assessed.

#### 4.4 Human Sperm Digital Images:

A fuzzy set  $S$  in a universe  $X$  is characterized by a  $X \rightarrow [0,1]$  mapping  $X_s$ , which associates with every sperm shape element  $x$  in  $X$  a degree of membership  $\chi_S(x)$  of  $x$  in the fuzzy set  $S$ . In the following, we denoted the degree of membership by  $S(x)$ . Note that a digital image can be identified with a fuzzy set that takes values on the grid points  $(x, y, z)$ , with  $x, y, z \in N, 0 \leq x \leq M$  and  $0 \leq y \leq N$  and  $0 \leq z \leq W$  ( $M, N, W \in N$ ). Therefore, for head, neck, and tail: H, N, T, we had that H, N, T  $\in f(X)$ , with  $X = \{(x, y, z) | 0 \leq x \leq M, 0 \leq y \leq N, 0 \leq z \leq W\}$  a discrete set of image points, where  $f(X)$  is the class of fuzzy sets over the universe  $X$ . The class of crisp sets over the universe  $X$  will be denoted by  $C(X)$  as the following measurements.

$$S_1(H, N, T) = 1 - (1/MNW \sum |H(x) - N(x) - T(x)|)$$

$$S_2(H, N, T) = 1 - (\sum |H(x) - N(x) - T(x)|) / (\sum (H(x) + N(x) - T(x)))$$

$$S_3(H, N, T) = 1 - 1/MNW * 3 \ln 3 * \sum [(H(x) - N(x) - T(x)) + (T(x) - N(x) - H(x))]$$

$$S_4(H, N, T) = |H \cap N \cap T| / |H \cup N \cup T|$$

$$S_5(H, N, T) = |H \cap N \cap T| / (\max |H|, |N|, |T|)$$

$$S_6(H, N, T) = |H \cap N \cap T| / (\min |H|, |N|, |T|)$$

$$S_7(H, N, T) = 1/MNW \sum [\min(H(x), N(x), T(x))] / \max(H(x), N(x), T(x))$$

A 3-CCD camera was used with 100 slides with LabView software tool to evaluate the efficiency of the proposed method. The fuzzy data fusion was used to simulate the percentage idea sperm of head, neck/mid-piece, and tail defects. The duplicated computing of 300 sperms shape groups of symmetrical, asymmetrical, irregular, and amorphous, with respect to head, neck, and tail parameters was performed. Once obtained the classification through the fuzzy method, the results have been submitted to qualitative judgment of the image data.

### 5. IMAGE BASED ON FUZZY FUSION

In order to analyze the images with different shapes of human sperms, the authors compared the results with the pixel-based measurements. We started with the variety of shape evaluations to proposed images quality measurements that were based on fuzzy data fusion and fuzzy set theory. Figure 4 was the example of fuzzy digital images of different properties.



**Figure 4. Recognition of integrating fuzzy fusion**

The images were taken with small overlapping areas of neighboring smear sites, so that the complete stripes were imaged, allowing to determine almost the same area as when calculating the shapes directly with the LabView as usual till now without acquiring images. Image acquisition was done with an automatic inverse microscope and a 3-CCD color TV camera. The digitized images were stored on the computer disk each with a size of 760 x 576 pixels. The pixel size results for the magnifications to 0.4  $\mu\text{m}$  and 0.7  $\mu\text{m}$  respectively. One fuzzy data fusion set comprised 300 images from 40x objective and 140 from 20x objective. Image analysis was performed by fuzzy data fusion with mathematical models and fuzzy fusion contract capabilities in Figure 5

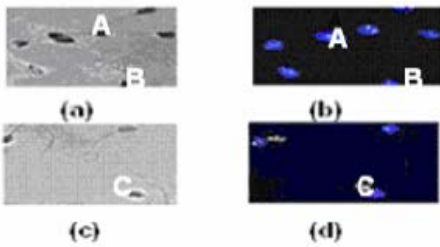
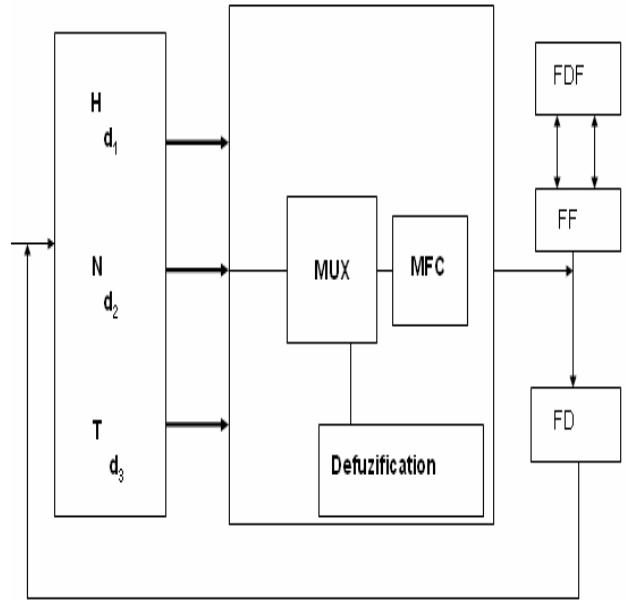

**Figure 5. (a) and (b) human sperm image contrast and (c) and (d) human sperm image contrast.**

A fuzzy fusion contrasts were designed for all analysis, display and supervision tasks.

## 6. RESULTS

In evaluating the effects of sperm shape in the 1300 human sperm studied, we digitized 500 fields of the sperm representing all classes in any man, while irregular and amorphous types.



**Figure 6. Fuzzy fusion behavior simulation.**

In Figure 6, we designed the simulation plant for the fuzzy fusion behavior. Fuzzy data fusion indicated that the sperm dimensions of area, perimeter, long axis and short axis were significantly increased after the image processing. Fuzzy data fusion was used for all sperm groups, whether they were symmetrical, asymmetrical, irregular or amorphous. They recognized the solution with different shapes as the readable and as that the better highlight the most meaningful morphological structures. This was simply the largest entry in the fuzzy fusion, and corresponds to the strongest responses. A measurement of the image contrast or the amount of local variation presents in an image. A measurement of the image is the detection randomness of intensity distribution in sperm properties. The membership functions have been characterized as Figure 7.

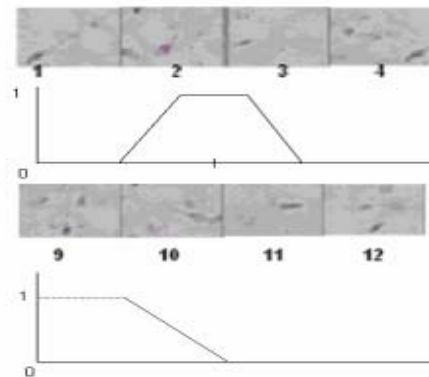

**Figure 7. Membership functions assessment of human sperm properties.**

In Figure 7, the membership function has higher values in rigid area, mainly convex, and lower values in the head bottom and near the neck. The membership function has higher values in the lower neck and where the shape is not too high. The

membership function has higher values in areas almost plain, with low height, and lower values in the body. For instance, the recognition of 3-CCD camera image uses the results of recognition of human sperm to illustrate the rough shape and localization in its fuzzy dilation to account for variability and for inexact matching between the model and the image. This knowledge was combined with information extracted from the image itself, which leads to a successful recognition of the normal and abnormal in fuzzy data fusion for human sperm in table 2 that it can be compared with table 1 in traditional microscope calculations.

**Table 1. Performance of the different shapes of sperm morphology**

Shape Levels		mean	Std
Best Individuals	H	70.63	0.24
	N	70	0.25
	T	68	0.21
Majority Individual	H	60	0.22
	N	60	0.56
	T	59	0.34
Average Individual	H	65	0.27
	N	62	0.21
	T	61	0.32
Poor Individuals	H	21.2	0.33
	N	15.6	0.45
	T	19.7	0.54

Head (H) Neck (N) Tail (T)

**Table 2. Performance of the different shapes of sperm morphology of fuzzy fusion methods.**

Shape Levels		Fuzzy Satimage data	Fuzzy Phoneme data
Best Individuals	H	80.63	75.13
	N	75.66	76.00
	T	80	75
Majority Individual	H	80	77
	N	80	76
	T	69	76
Average Individual	H	75	78
	N	72	76
	T	81	76
Poor Individuals	H	65.2	76
	N	50.6	72
	T	20.7	73.21

Head (H) Neck (N) Tail (T)

Each image from a set of human sperm properties including the shapes was computed, which was then subjected for evaluation and further analysis. The images were labeled for object recognition. The images results demonstrate how these findings facilitate approaches on the 100 semen samples. The average

probability of morphology recognition analysis was equal to 95% and the average probability of unknown parameter was equal to 4.5%. Fuzzy data fusions show that we were successful in our recognition of human sperm into different shape groups. The percent increased for each of the categories, such as head, neck, tail area, perimeter, long axis, and short axis were quite similar, except for a larger percent increase in the mean head, neck, and tail area in the their shape properties.

## 7. CONCLUSIONS

In analyzing the fuzzy fusion results, the authors confirmed the fuzzy fusion for the viable solution in reducing and controlling both the variability and the subjectivity of the classifications of human sperm morphology data. This technique predicted the shape of human sperm with 95% accuracy on a test set of 1300 images. The authors have also shown the usefulness of fuzzy fusion morphology in this context. This work opened the new perspectives for spatial reasoning under imprecision in image interpretation. The authors proposed a new approach based on image analysis that allowed us to classify the shapes by images digitalized. Accuracy may be improved using larger fuzzy test sets. In perspective, the authors could use this low cost methodology to examine images rapidly using a microscope with 3-CCD camera. It showed very clearly from the present data that human sperm shape was preserved not only visually but also by objective morphometry after digitizing image process. Further studies are needed in order to access the correlations between fuzzy fusion and manual analysis.

## 8. REFERENCES

- [1]. Seracchioli, R (1995). **The diagnosis of man infertility by semen quality**. Hum. Reprod. 10, 1039-1041.
- [2]. Van, Uem JFHM and Swanson RJ (1985). **Male factor evaluation in in vitro fertilization**: Norfolk experience. Fertil Steril;44:375-83.
- [3]. Knuth, UA, and Nieschlag, E. (1988). **Comparison of computerized semen analysis with the conventional procedure in 322 patients**. Fertil Steril;49:881-5.
- [4]. Karen, G. Hales(1997). **Developmentally regulated mitochondrial fusion mediated by a conserved, novel, predicted GTPase**. Cell, Vol. 90, 121-129, July 11.
- [5]. Hermann, Kopp-Borotschnig (1996). **A new concept for active fusion in image understanding applying fuzzy set theory**. Fuzzy IEEE, New Orleans.
- [6]. Rusan, S.(2002). **Fuzzy markovian segmentation in application of MRI, and computing vision and image understanding** 85, pp. 54-69.