

The Virtual GloveboX (VGX): a Semi-immersive Virtual Environment for Training Astronauts in Life Science Experiments

I. Alexander Twombly
University Space Research Association
MS 239-11, Moffett Field, CA 94035, USA

Kevin Montgomery
National Biocomputation Center
701 Welch Rd. Suite 1128, Palo Alto CA 94034, USA

Jeffrey Smith*
NASA Ames Research Center
MS 239-11, Moffett Field, CA 94035, USA

Richard Boyle
NASA Ames Research Center
MS 239-11, Moffett Field, CA 94035, USA

ABSTRACT

The International Space Station will soon provide an unparalleled research facility for studying the near- and longer-term effects of microgravity on living systems. Using the Space Station Glovebox Facility - a compact, fully contained reach-in environment - astronauts will conduct technically challenging life sciences experiments. Virtual environment technologies are being developed at NASA Ames Research Center to help realize the scientific potential of this unique resource by facilitating the experimental hardware and protocol designs and by assisting the astronauts in training. The "Virtual GloveboX" (VGX) integrates high-fidelity graphics, force-feedback devices and real-time computer simulation engines to achieve an immersive training environment. Here, we describe the prototype VGX system, the distributed processing architecture used in the simulation environment, and modifications to the visualization pipeline required to accommodate the display configuration.

Keywords: Virtual Reality, NASA, Glovebox, Training, Virtual Environment, Simulation, VR

INTRODUCTION

Onboard the International Space Station, complex life science experiments will address long-standing questions concerning life's ability to adapt and respond to the space environment. Many of these experiments will require astronaut intervention and the use of the Life Sciences Glovebox Facility (LSG). Within the LSG, astronauts manipulate scientific instruments, conduct experimental assays, collect tissue specimens and perform delicate dissections—all under highly controlled conditions and while physically tethered to minimize drift and within strict time constraints. The experiments often demand very detailed training and knowledge of instrumentation, surgical anatomy and specific scientific objectives. To be successful, astronauts must remain highly proficient in these experimental techniques, but due to scheduling constraints they can receive only limited Earth-based training with real LSG mock-ups and real experimental specimens. Because of mission costs, crew safety, and the immediate and far-reaching impact of the scientific results, it is imperative that novel strategies be developed to maximize the use of the LSG Facility.

The use of the glovebox as an isolation system for space-based research is not new. Gloveboxes of various sizes and capabilities have flown as payloads on a number of Shuttle

science missions [1]. Today, the Destiny Lab module of the International Space Station (ISS) houses one of the most sophisticated glovebox facilities yet to fly in space. The Microgravity Sciences Glovebox is currently being used for a series of materials science, micro-physics and bio-processing experiments. The MSG has an enclosed volume of 255 liters and a floor space about 80 cm wide by 60 cm deep [2].

For tasks aboard ISS requiring a larger glovebox work volume, the LSG will be used. When delivered to the Space Station, the LSG will be the largest, most complex glovebox system ever flown. Glove ports on two sides let up to two astronauts work simultaneously in the LSG which has a containment volume of nearly half a cubic meter and a floor space about 100 cm wide and 60 cm deep [3]. When extended from the Space Station rack in its deployed position, as shown in Figure 1 the LSG will provide the crew with a pull-out workbench for performing biology experiments in space. It is equipped with holding racks and an air-lock attachment for contained specimen transfer. A suite of experiment-unique equipment and supplies have been developed that take into account the microgravity environment in space and the unique constraints imposed on the astronauts both from environmental restrictions and through the glovebox interface. Astronauts who must perform LSG experiments in space are faced with achieving a very high level of proficiency on a suite of complex hardware with very little time to train. In addition, the inherent complexity of biology research increases the need for highly skilled and experienced operators. With



Figure 1: The Life Sciences Glovebox Facility (LSG) located in the Space Station Rack. The LSG is a pull-out enclosed workspace for isolating chemical and biological samples during space-based research experiments. Up to two astronauts may work in the glovebox at once. Power, video and data interfaces allow for a suite of lab equipment to be used. Deployment to the Space Station is currently scheduled for 2008.

* Corresponding Author
Email <Jeffrey.D.Smith@nasa.gov>

that, the need for high-fidelity computer-based training using the Virtual Glovebox becomes the best means to augment current training activities and streamline the process for both astronauts and support teams.

Today, astronauts prepare for life science experiments through a series of training videos, visits with scientists and practice experiments using Earth-based mock-ups and real biological specimens. The opportunities for these full-scale mock experiments are rare and, due to the heavy work loads astronauts face when preparing for their missions, it may be weeks or months between their last practice experiment and the actual procedure performed in space. Developing crew training requirements for specific payloads is a significant challenge, and making training efficient is essential to provide focus on safety and research objectives. Technologies like the VGX will build on the current training schedules of astronauts and promise to reduce required training time and the number of live specimens required for preparatory experiments [4].

A semi-immersive computer-based aid to training astronauts for future biological research in the LSG, called the “Virtual GloveboX” (VGX), is being developed at NASA Ames Research Center [5]. Astronauts and support crews can use the VGX for early engineering development and experiment planning, and later advanced training activities that require the LSG. The system integrates off-the-shelf hardware and software with new real-time simulation technologies to provide a realistic 3-D virtual environment, mimicking the real LSG environment. Within the VGX, the force of gravity can be turned on and off, allowing astronauts to perform experiments in a simulated microgravity environment while still on Earth. Further, a continuum of scenarios from ideal conditions to catastrophic experiment failures, such as contamination, can be introduced into the training session to allow the astronaut and principal investigator to assess critical decisions. The VGX does not eliminate the need for direct, hands-on training and experiment planning using physical mock-ups; however, it can streamline these processes, reduce the need for full-scale training sessions with live animals, increase the frequency and ease of the principal investigators input to their specific experiment, and provide astronauts with a means to keep their skills sharp on Earth and in space, thereby maximizing the efficiency and success of ground-breaking biological experiments in space.



Figure 2: A Stereoscopic Display Station uses two digital projectors and polarized optics to provide a high-resolution immersive environment of about the same size as the working space of the Life Sciences Glovebox Facility.

VIRTUAL GLOVEBOX SYSTEM (VGX)

The VGX is composed of a package of virtual environment technologies that sets high standards for speed, resolution and desktop user-interface immersion. Unlike any commercial product or research prototype before it, the VGX is designed to combine real-time graphics, force-feedback haptics and hand tracking in an immersive desktop environment that is registered with physical space. The VGX hardware and software were assembled specifically for engineering development, experimental design and astronaut training for the Space Station Life Sciences Glovebox Facility (LSG), but the system is also versatile and could be used for other virtual environment simulations and training that occur in a desktop-sized volume.

A Stereoscopic Display Station is used to provide an immersive virtual environment for the VGX simulation software (Figure 2). The Stereoscopic Display Station is currently designed to use twin LCD projectors with circular polarization options to provide high-resolution images (1280 x 1024 pixel resolution) while maintaining a compact display structure. The image projected into the box falls on a flat 40”x30” screen that is above the user’s arms. The user looks down onto a front-projected screen in the Display Station, and with the use of lightweight circularly polarized stereo glasses a 3D virtual environment 40” wide, 30” deep and 24” in height is created for user interaction and visually overlaid with the physical structure of the VGX enclosure. This internal working space of the Stereoscopic Display Station is almost identical to the space inside the LSG, which is scheduled to fly aboard the International Space Station. In contrast to other “reach in” virtual environments that use a monitor and a mirror to create the reach in space, the use of a front projected screen allows the image to remain in a stable position on the display when the user moves their viewing point. This stable, full screen image is what allows the display to be visually overlaid with the glovebox enclosure, increasing the sense of immersion by aligning the perceived glovebox walls and floor with the real glovebox structure.

Inside the desktop of the VGX, the user will be able to interact with virtual objects through a pair of Cybergloves® (Immersion Inc.) that are tracked in the virtual environment using magnetic trackers (Ascension Technology Inc.). The operator inserts his/her hands through the front armholes of the box and into the gloves. A virtual representation of the user’s hands are shown on the viewing screen in the box and are registered with the real position of the user’s hands in the working volume. Desktop PHANToM™ force feedback devices (SensAble Technologies Inc.) provide a three-degree-of-freedom haptic interface to the user. Virtual tools in the environment that require force feedback for their proper use can be associated with the PHANToM device and can be picked up by the user. Registration of the virtual environment to the physical space within which the user works requires that the VGX display be tracked to the position and orientation of the users viewpoint (*i.e.*, eyes), restricting the use of the VGX to a single operator. However, the distributed design of the simulation environment allows for multiple users from separate VGX systems to interact in the same virtual environment, simulating the multi-participant scenarios anticipated for training and complex experimental protocols.

GENERAL ARCHITECTURE

The simulation and visualization software for the VGX is designed around a networked cluster model to allow maximum performance and scalability for each component of the system.

The system consists of three major subsystems: 1) A simulation engine to monitor and calculate interactions of the objects in the virtual environment, 2) peripheral device controllers to allow interaction of the user with the virtual environment, and 3) a display system to visualize the virtual world at multiple workstations. Currently, the core simulation engine and peripheral device controller is the *Spring* simulation environment developed with the National Biocomputation Center at Stanford University [6]. This physically based modeling system is coupled with a highly efficient collision detection algorithm to allow a rich set of 3D objects to interact with one another and the user via virtual representations of the peripheral devices. Some simple rigid body interactions allow for manipulations of virtual laboratory equipment – the user can pick up and move objects, practice setup/break down procedures, and arrange equipment within the environment during feasibility studies. More complex interactions can be had through a real-time deformation engine used to simulate soft-tissue interactions (e.g., surgical simulation). The peripheral devices (Cybergloves, PHANToMs) communicate with the simulation engine via a network interface, allowing each device to be controlled by a separate computer without regards to proximity to the simulation engine or display systems. The orientation and movements of each peripheral device are registered with the virtual environment, mapping each device to the world coordinates of the virtual environment. A specialized visualization subsystem was created to accommodate the unique architecture of the VGX display and off-load the visualization processing from the main simulation system. This visualization system consists of a data replicator that sends the changing geometric information from the simulation engine to the display systems, a custom stereo rendering system to address the twin LCD projectors, and a post-processing facility within the display systems to enhance the geometric data for display.

DISPLAY SUBSYSTEM

The stereoscopic display of the VGX dual projector system is achieved by creating a virtual display space on a single dual output graphics card (using the nVidia Quadro4 graphics chipset), implemented in OpenGL. This display space is achieved through three components: 1) a mapping of the left- and right-eye view that can be displayed through the dual output system of the graphics board, 2) a geometry replicator that receives all 3D geometric data from the simulation engine via a network interface, and 3) a viewpoint tracking system used to create the viewport mapping for each eye to the display. All communications are performed over a high-bandwidth network (preferably Gigabit Ethernet) to maintain the performance of the rendering system.

The mapping of the left- and right-eye views to the dual output of the graphics card requires architecture different from that typically used in OpenGL stereo display systems. The dual outputs of the graphics card are configured to be horizontally concatenated, providing a side-by-side display that is (2x1280) x 1024, with each output displaying a 1280x1024 portion of the display. Rather than using an OpenGL dual buffer system that explicitly allows the left-eye viewpoint to be drawn in one buffer, and the right-eye in the other, we use a single buffer that is twice the width of each view, and draw the left viewpoint on one side and the right viewpoint on the other. Thus for a display system configuration that requires each projector to receive an 1280x1024 image, the left-eye viewpoint is rendered to the display buffer in the range (0-1279,0-1023) and the right

eye viewpoint is rendered to the display buffer in the range (1280-2559,0-1023), and each of the outputs on the graphics card shows precisely one eye's viewpoint. The advantage to this method are both that the display of the left and right eye images are fully synchronized in their display timing which effectively genlocks the projectors, and the display can be generated from a single PC using a dual output graphics card which eliminates the need to coordinate the display between different computers for the two different projectors.

The geometry replicator is a high-bandwidth connection between the display computers and the simulation engine used to move the geometric data from the interactive environment to the display environment. This is a strict Client/Server model, with information flowing from the simulation engine to the display systems. Using a Gigabit Ethernet connection, the simulation engine can effectively move as much data to the display systems as possible sending directly across a PCI bus to an internal graphics card. Upon initialization of the system, all the geometric data within the simulated environment is sent to the display systems to create the initial visual environment. Since the optimal organization of the geometric data is different for the simulation engine and display systems, the display systems reorganize the data to map it as efficiently as possible to the graphics system available. During subsequent modifications of the data during user interactions in the simulation environment (e.g., object movements, soft tissue deformations, cutting [7, 8, 9]) only the modified geometry is replicated to the display systems. Because the simulation and interaction engine operates strictly on geometric primitives, it is left to the display system to implement how the data should be presented to the user. This allows the display to take advantage of the features of today's newest graphics cards (multi-pass texture processing, bump mapping, vertex and/or pixel shaders) without impacting the performance of the simulation itself. This approach provides a means for creating a significantly richer visual presentation than that required for calculating the physical interactions, and allows the display systems to take advantage of any specific graphics hardware available at each display station participating in the simulation.

The viewpoint-tracking component is required to compensate for the users constantly changing position and orientation to the display screen. Because the location and orientation of the screen relative to the user's eye deviates significantly from the standard perspective view, a series of modifications to the viewport mapping must be made for each eye to generate a visual image that is consistently registered with physical space. A typical viewing point would place the user at a relative angle to the screen of nearly 45 degrees, creating substantial distortions in the image relative to the standard flat screen model. Projecting a line from the user's eye perpendicular to the viewing plane, an asymmetric viewing frustum can be defined to match the physical location of the corners of the display and passed to the rendering engine, and continually updated via the tracking system. Due to the proximity of the user to the large viewing surface, a viewing frustum unique to each eye must be maintained for proper stereo viewing.

When used with the LCD projectors, the display system requires a final adjustment phase to fine tune the image alignment between projectors. Because the LCD's lack the internal functions to modify the projected image found in high end CRT systems, the precise pixel-to-pixel alignment required for effective stereo is difficult and time consuming to achieve through physical adjustment of the projectors. An efficient method of compensating for image misalignment on today's PC

graphics hardware is to take advantage of off-screen rendering and texturing optimizations. Assuming the distortions between images are small, a rectangular grid can be projected to fill the viewport, and the position of each grid point can be modified slightly to correspond between images. Rendering the scene to an off-screen buffer and then projecting this image onto the grids via the texture buffer provides a high degree of alignment, and significantly reduces the work required to setup and maintain the display system.

DISTRIBUTED GRAPHICS PERFORMANCE

The performance of the graphics subsystem is strongly dependent on the simulation engine, and the speed of data replication that can occur. In the *Spring* simulation system, all of the geometric primitives of an object are updated for any modification of the position or orientation of an object. This design reflects the emphasis on soft-tissue dynamics in the simulator that stress modifications of the shape of objects, and efficiently packages the data to allow such operations. In a typical application in the VGX, several objects with a total of ~10,000 – 15,000 geometric primitives (triangles) will be in motion and replicated to the display system. Geometry updates of 15 – 20 frames per second are achieved with such a data load, with the graphics system providing a rendering rate of greater than 35 fps for all objects (stationary and dynamic) in the scene. If the projectors are physically aligned to allow an accurate stereo overlay on the screen, the effective rendering speed is sufficient to allow smooth motion at 35 fps. However, a significant performance drop is taken when creating the display through the texture buffer, which requires moving large amounts of data across the graphics bus. We have achieved a consistent 6 or more frames per second with this technique for 1280x1024 images, rendering each eye view to the texture buffer and then applying the texture to a 128x128 grid to perform fine spatial alignment between the images. Due to the limited rendering rate, this technique is only used for simulations with a high degree of fine spatial detail.

CURRENT SIMULATIONS AND FUTURE DIRECTIONS

A variety of models preceded the current state of the LSG design (Figure 3). A large assortment of 3-D tools and instrumentation are now available to replicate the precise objects used in the actual experiments (a few are shown in Figure 4). For simulating advanced biomedical experiments in the VGX an anatomically based 3D model of a rat, using high resolution CT scans was developed [10]. Extensive development of the *Spring* simulation engine [6, 7, 8] has demonstrated the ability to deform and cut simulated tissue in real-time using the PHANToM force-feedback devices, viewed from both a standard monitor and within the VGX using the geometry replication techniques. Additional simulation engines that perform only rigid body interactions have also been tested [5], allowing operational feasibility studies to be performed to determine equipment placement and management in a microgravity environment.

Continued development of the VGX subsystems will increase the utility of this simulation system for enhancing the extent and quality of life sciences experiments conducted in space. Improvements in the fidelity of the registration of the visual world with the physical world could substantially increase the illusion of immersion in the workspace. The user interface for the VGX must be intuitive or it will not be useful as a realistic

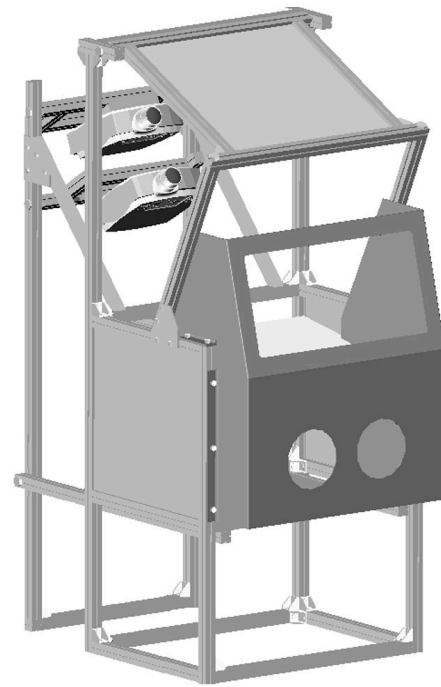

Figure 3: Virtual Glovebox Display Station. *The display station is constructed from plastic and aluminum. Two LCD projectors reflect off a mirror onto a silvered screen to provide stereo imaging capabilities. Arm holes in front may be used or the front panel can be removed for a more desk-top like virtual environment.*

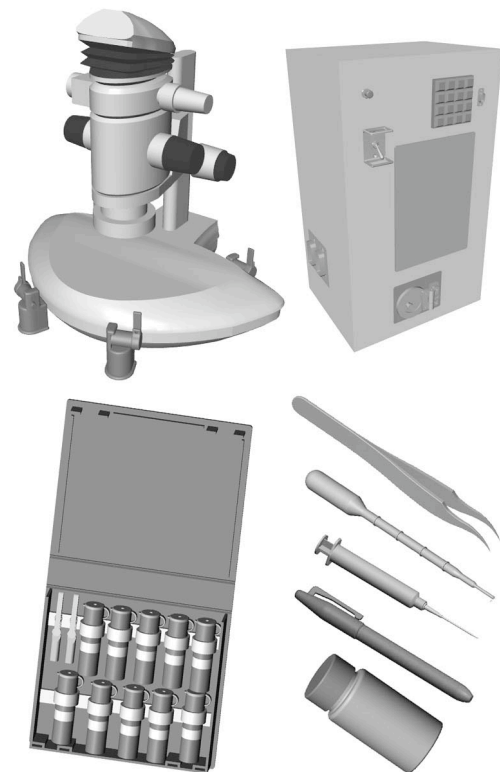

Figure 4: Examples of tools and equipment available for the VGX: *a) stereo-microscope, b) mass measuring device, c) plant pollination kit and d) lab tools. Objects are not to scale.*

training tool. The current interface, using off-the-shelf virtual reality tracking and haptic feedback systems has cumbersome elements such as wired gloves, tethered magnetic trackers and haptic armatures inside the workspace. Further research will help reduce the need for encumbered interface devices and increase the value of the VGX as a virtual environment training tool. Finally, the graphics processing capabilities of the display subsystem must be utilized to a greater degree to include photo-realistic texturing, bump map lighting, and other advancements at the graphic hardware level to enrich the visual environment and reinforce the illusion of immersion.

CONCLUSIONS

The Virtual Glovebox is a virtual environment application designed to provide a realistic Life Sciences Glovebox training experience for astronauts that simulates the scientific experiments that will be conducted aboard the International Space Station. The Virtual Glovebox provides a high-fidelity virtual environment training tools by combining high resolution computer graphics with magnetic tracking and haptic feedback devices in an immersive desktop environment. The distributed design of the VGX system provides the benefits of a widely distributed multi-user system, resource conservation to improve processing speeds, and techniques for accessing the most recent advances in PC graphics while retaining a simulation engine on a high end multi-processor workstation. This provides a high level of realism to a user who can intuitively perform experimental tasks in a real-time microgravity or nominal 1-g simulation. Determining operational efficiencies for LSG equipment, optimal experimental design and simulation for training and evaluating operator performance are all VGX applications that will streamline processes associated with performing biology research in space. In this way, the NASA VGX advances existing LSG experiment planning, operations, training and trouble-shooting methods for astronauts and support crews, thus, helping to maximize the scientific return gained from future biological research in space.

ACKNOWLEDGEMENTS

The authors would like to thank Julian Durand of the International Space University (France), Dr. Simon Wildermuth of the University of Zürich (Switzerland), Anil Menon, Robert Barnes, Rose Mills, Jennifer Magpayo, and CJ Slyfield for contributions to this ongoing research. This work was funded by NASA Ames Research Center, Division of Life Sciences.

REFERENCES

- [1] J. D. Smith, "The Virtual Glovebox (VGX): an Immersive Simulation System for Training Astronauts to Perform Glovebox Experiments in Space," **Enclosure**, Vol 15, 2002, pp. 8-13.
- [2] C. Baugher, "The Microgravity Science Glovebox," **AIAA Conference on International Space Station Utilization**, AIAA paper 2001-5089, 2001.
- [3] O. Santos, G. Meeker and S. Hing, "The Space Station Biological Research Project: Mission, Goals, and Status," **AIAA Conference on International Space Station Utilization**, AIAA paper 2001-4983, 2001.
- [4] P. D. Savage and J. D. Smith, "Utilization of Virtual Environments for Astronaut Crew Training," **SAE Technical Paper Series**, 2000-01-2361, 2000.
- [5] J. D. Smith, I. A. Twombly, C. Bruyns and R. Boyle, "NASA Virtual Glovebox (VGX): Training and Simulation for Biology Research Aboard the International Space Station," **AIAA Conference on International Space Station Utilization**, AIAA paper 2001-5105, 2001.
- [6] K. Montgomery, C. Bruyns, J. Brown, G. Thonier, A. Tellier and J. C. Latombe, "Spring: A General Framework for Collaborative, Real-Time Surgical Simulation," **Medicine Meets Virtual Reality 02/10**, Vol. 85, 2002, pp. 296-303.
- [7] C. Bruyns and K. Montgomery, "Generalized Interactions Using Virtual Tools Within the Spring Framework: Cutting" **Medicine Meets Virtual Reality 02/10**, Vol. 85, 2002, pp. 79-85.
- [8] C. Bruyns and K. Montgomery, "Generalized Interactions Using Virtual Tools Within the Spring Framework: Probing, Piercing, Cauterizing, and Ablating," **Medicine Meets Virtual Reality 02/10**, Vol. 85, 2002, pp. 74-78.
- [9] C. Bruyns, S. Senger, K. Montgomery and S. Wildermuth, "Real-Time Interactive Cutting Using Virtual Surgical Instruments", **Medical Image Computing and Computer-Assisted Interventions (MICCAI 2001)**, Utrecht, The Netherlands, October 14-17, 2001.
- [10] C. Bruyns, K. Montgomery and S. Wildermuth, "A Semi-Immersive Virtual Environment for Simulated Rat Dissection," **Proceedings of Visualization 01**, 2001, pp. 509-514.